



**FIXED ASPIRATOR
FOR NAIL FILING POWDERS**

“HELIOS 280”

REVISION TABLE

REVISION	DATE	NOTE
0.0	03/02/2021	FIRST EDITION





INDEX

GENERAL PROVISION	4
• <i>Introduction</i>	4
• <i>Customer service</i>	4
GENERAL WARNINGS	5
• <i>Intended use</i>	5
• <i>Environment Limit</i>	5
• <i>Expected shelf life</i>	6
• <i>Identification</i>	6
DECLARATION OF CONFORMITY	7
SAFETY	8
• <i>Safety Standards</i>	8
• <i>Definitions</i>	8
• <i>Legend of the used symbols</i>	8
• <i>General provisions</i>	9
• <i>Description of the device</i>	10
• <i>Name of the main parts</i>	10
• <i>Description of the main parts</i>	11
TECHNICAL FEATURES	12
• <i>Technical data</i>	12
• <i>Electrical data</i>	12
INSTALLATION	13
• <i>Transport and delivery</i>	13
• <i>Storage</i>	13
• <i>Installation</i>	14
• <i>Preparation of installation area</i>	14
• <i>Equipment check</i>	14
• <i>Installation procedures</i>	14
• <i>Unpacking</i>	15
• <i>Assembly</i>	15
• <i>Electrical connection</i>	15
• <i>Power grid connection procedure</i>	16
• <i>Functional testing</i>	16
OPERATION AND USE	17



• Warning:	17
• Starting, regulation and turning off	17
CLEANING AND SANITIZATION	18
• Cleaning	18
• Cleaning of the filters	18
• Filter replacement	18
• Sanitization	18
• Cleaning intervals and sanitizing	18
MAINTENANCE	19
• Periodic test	19
• Extraordinary maintenance	19
• Technical assistance	19
• Dismissal	20
• Demolition and disposal	20
WARRANTY	21
F.A.Q.	21
WIRING DIAGRAM	22



GENERAL PROVISION

• Introduction

This User Manual is intended to provide the user with all the necessary information to properly use and manage the machine as independently and safely as possible.

This manual includes information on technical aspects, operation, machine downtime, maintenance, spare parts and safety.

For your protection, please carefully read these warnings and instructions completely, as they provide important information regarding **SAFE USE AND MAINTENANCE**.

Before carrying out any operation on the machine, operators and qualified specialists must carefully read the instructions contained in this Manual.

In case of doubts about the correct interpretation of the instructions, contact your dealer in order to receive explanations.

The descriptions and illustrations provided in this publication are not binding.

Vismara srl reserves the right to make any changes it deems convenient for improvement purposes, without undertaking to update this publication.

The illustrations and images in this manual are intended as examples only, and may differ from actual situations.

This manual is an integral part of the machine, it must be kept with the utmost care by the purchaser, it must be placed in the immediate vicinity of the machine, inside a special container and, especially, away from liquids and anything else that could compromise the state of readability.

The manual must accompany the machine if sold to a new user.

It is forbidden for anyone to disclose, modify or use this manual for their own purposes.

The safety of the operator and the customer and proper operation depend on compliance with the instructions described here.

• Customer service

Customer service and product support are important aspects of the corporate structure of Vismara srl.

The dealer is available for further information on the use, maintenance and customer service of this product.



GENERAL WARNINGS

The product described in this Manual is manufactured by:



Vismara s.r.l

Via Salvo d'Acquisto, 19

20833 Paina di Giussano (MB)

Tel: +39 0362 236169

• Intended use

- **Type of device:** Fixed aspirator for nail filing powder “Helios 280”.
- **Usage environment:** beauty salons, spas, beauty shops and beauty farms.
This machine is suitable for collective use, for example hotels, schools, hospitals, factories, shops, offices and residences.
The location must be equipped with an electrical system compliant with current regulations.
- **Personnel intended to use the product:** specialists. Fixed aspirator for nail filing powder “Helios 280” cannot be used by people with reduced physical, sensory or mental abilities.
- **Supervision and responsibility:** Aspirator “Helios 280” must be used under the supervision of a specialist.
- **Warning:** Aspirator “Helios 280” cannot be used in a potentially explosive or flammable atmosphere.
- **Usage limit:** The aspirator can only be used as described in this manual. It is necessary to provide an adequate air exchange in the room if the exhaust air returns to the room itself. It is necessary to refer to national regulations.

• Environment Limit

WARNING! *The table cannot be used in a potentially explosive or flammable atmosphere.*

The environmental working conditions must follow the following indications:

- Temperature: 10° C ÷ +35° C
- Humidity: 50% ÷ 90%.

The product must be placed in a completely dry space.

Environmental conditions other than those indicated can cause serious damage, particularly to electronic equipment.

Placing the aspirator “Helios 280” in incorrect locations will void the warranty.



- Expected shelf life**

Aspirator “Helios 280” has been designed and built to function without risk for things and people under the ordinary conditions of use, defined in this manual, for 5 years. However, this duration can only be reached by following the requirements contained in this manual and by contacting the technical assistance in the event of mechanical failures. After 5 years of its use, the manufacturer recommends a replacement.

- Identification**

WARNING! Do not remove the label from the device for any reason.

The item is identifiable from the label placed on the base, which contains the following data:

1. Company Logo	8. Consult instructions for installation and use
2. Name and address of the manufacturer	9. IP code
3. CE marking	10. Voltage, utility frequency
4. Manufacturing data	11. Absorbed power
5. Serial number	12. Frequency
6. Item name	
7. Safe working load	

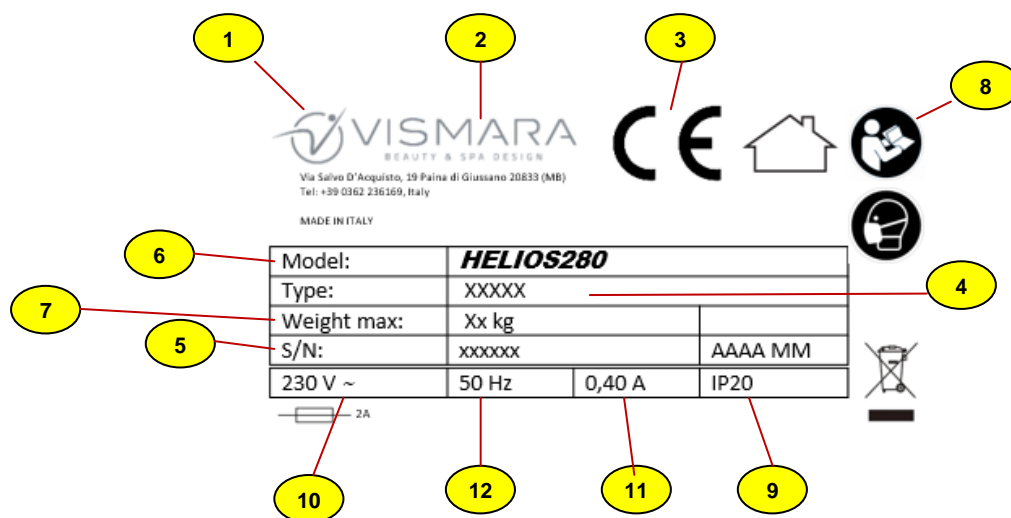



DECLARATION OF CONFORMITY



CE DECLARATION OF CONFORMITY

(Annex IIA DIR. 2006/42/CE)

THE MANUFACTURER

VISMARA s.r.l.

Company

Via Salvo d'Acquisto, 19

20833

MB

Address

Zip code

Province

Paina di Giussano

Italy

City

Country

DECLARES THAT THE MACHINE

FIXED ASPIRATOR FOR NAIL FILMING POWDERS

HELIOS 280

Machine

Model

IS COMPLIANT WITH

We declare under our own responsibility that the devices covered by this declaration comply with the essential requirements indicated by the following Community Directives:

Directive 2006/42/CE of the European parliament and Council dated 17 May 2006 concerning the machines and which modify the directive 95/16/CE,

Directive RoHS 2011/65/UE

References harmonized standards

Reference of the main harmonized standards: EN60331-1

Vismara Cristian
Sole Administrator



SAFETY







- **Safety Standards**
- **Definitions**

This Manual will use the following terms regarding safety:

- Danger zone:** any area inside and / or near the device, in which the presence of an exposed person constitutes a risk to the safety and health of that person.
- Exposed person:** any person who is completely or partially in a danger zone.
- Operator:** the person in charge of installing, operating, regulating, maintaining, cleaning, repairing, and transporting the machine.
- Vismara s.r.l.'s Dealer:** a specialist made available by the dealer or its agent to perform complex operations, installation and commissioning.
- Safety components:** any component especially designed by the manufacturer and marketed separately from the machine in order to perform safety functions; this component can be defined as a “safety component” when its failure jeopardizes the safety of exposed people.

- **Legend of the used symbols**

Here below the used symbols with their meaning:

	Warnings symbol
	Carefully read use and maintenance instructions
	Obligation to put on the face mask
	Do not dispose as domestic waste
	For internal use only
	Fuse



- **General provisions**

WARNING! *Improper use and maintenance can cause damage to people and things*

Operators have to carefully read this manual, follow its instructions and familiarize themselves with the proper usage and maintenance procedures.

Use and maintain this device only in accordance with the instructions provided by this manual, in addition use only genuine parts.

Do not use the device for conditions or purposes other than which it was intended.

Never leave the device unattended when the customer is lying on it.

Save this manual for future consultation and to support staff training.

The manual must accompany the machine if sold to a new user.

The staff must be informed and trained in the use of the device and also about the safe way to remove the accumulated material.

When the machine is not in use, before starting maintenance or cleaning and before replacing the filter, always pull out the plug. To remove the plug from the socket do not pull by the electric cable.

Protect the electric cable from heat, oil or sharp edges.

In case of mains voltage interruption it is necessary to put the switch to OFF in order to prevent the aspirator from starting accidentally when the power is back.

Do not expose the machine to rain or low temperature.

In case of sale or passage to new users, transfer it with the product.

Carefully read the instruction manual before using HELIOS 280 for the first time.

WARNING! *Danger of explosion or fire*

Flammable or explosive powder must not be sucked

Do not suck up sparks or hot chips;

In case of powder leak from the aspirator, immediately disconnect the aspirator from the mains supply.

Any kind of liquid must not be aspirated.

WARNING! *It is not intended for any use other than that described in this manual.*

It is absolutely forbidden to use Helios 280 or parts of it for purposes other than those intended.

It is absolutely forbidden to replace parts or components of the vacuum cleaner not approved by Vismara srl.

It is absolutely forbidden to tamper with and / or modify the machine.

The manufacturer cannot be held responsible under any circumstances for accidents or damage resulting from improper use of the product.



GENERAL DESCRIPTION

- Description of the device**

HELIOS 280 fixed aspirator for nail filing powders was designed for use in beauty centers.

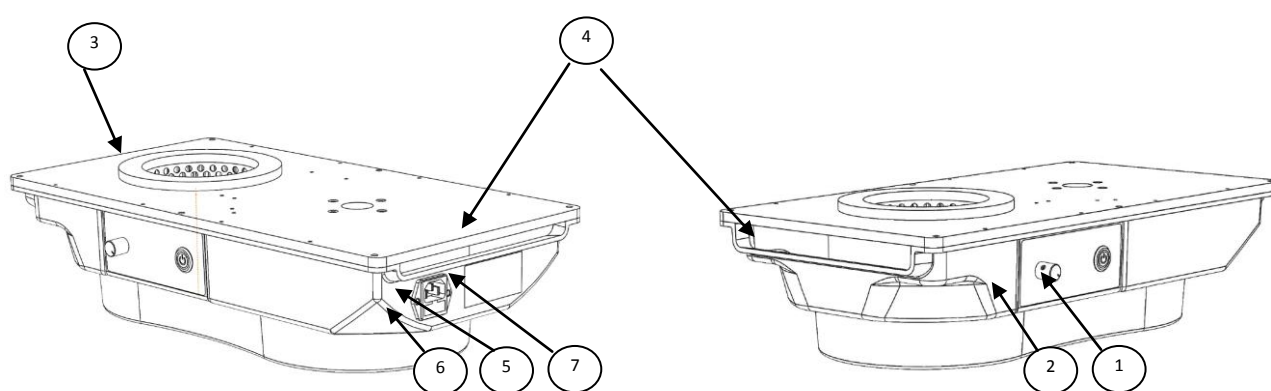

- Name of the main parts**

1 On – Off switch	5 Power cable connector
2 Suction power regulation knob	6 Fuse housing
3 Air filter	7 Technical data plate
4 Sucked air exits	



- **Description of the main parts**

1. On- Off switch

The product is equipped with a mechanical steel button with RGB LED for status indication. By pressing the button it is possible to turn on the aspirator. By pressing and holding the button for at least 3 seconds, the product can be switched off. During the pressing, a blue led lights up, indicating that the machine is running.

2. Suction power regulation knob

The suction power can be increased turning the knob clockwise. Turning the handle counterclockwise you can reduce the suction power.

3. Air filter

Active carbon filter. Make sure it is fully inserted before turning on the machine.

4. Sucked air outlets

Side openings that allow the sucked air to escape.

5. Power cable connector

6. Fuse housing

7. Technical data plate

Plate showing the technical data of the aspirator "Helios 280". The shown details are the same of the ones written in the given section of the manual. Therefore please read it.



TECHNICAL FEATURES

- **Technical data**

ASPIRATOR HELIOS 280		
Weight	Kg	3.7
Length (A)	mm	500
Width (B)	mm	300
Height (C)	mm	150



- **Electrical data**

ASPIRATOR HELIOS 280		
Input Voltage	VAC	230
Frequency	Hz	50-60
Operating voltage	VCC	220
Maximum absorbed electric current	A	0,4
Sound power level emitted under load	dB	64,8
Electrical protection class	-	I
Degree of protection against dust and water	IP	20
Max. Capacity (air)	M ³ /h	280

The noise issued by Helios 280 does not exceed the value of 70 dB, then it is not necessary to use protective headphones during the phases of use.

NOTE: It is necessary to respect the technical data shown on the product label to safeguard the integrity of all Helios 280 components.



INSTALLATION

The handling activities described in this chapter must be carried out exclusively by qualified personnel, in order to perform the loading, unloading and handling of packages in complete safety, The local personnel must be aware of the accident prevention regulations.

- **Transport and delivery**

The considerations for occupational safety remain valid.
The device is delivered assembled, inside a carton box packaging.

WARNING! *Upon receipt of the product, check with the courier/carrier that it is intact, that it has not been damaged during transport or that it has not been voluntarily opened to remove inside parts. Check that the supply corresponds to the order specifications and check with the shipping documents that the delivery is complete.*

If the packaging is externally damaged, open everything in the presence of the courier/carrier and check that the device has not been damaged.

Note any damage on the shipping documents and notify your dealer immediately.

If the packaging doesn't show any anomalies, check the device externally within 24 hours of delivery anyway.

In case of visible damage due to the transport, immediately inform the courier/carrier and the dealer, as well as Vismara s.r.l.

- **Storage**

In case of prolonged storage, store the device in a dry place, protected from rain and wind.

Above all, protect the electrical parts and all parts sensitive to ambient humidity and low temperatures.

Store in dry places, between -10°C and + 70°C and relative humidity 20% ÷ 90% no condensation.



• Installation

The installation takes place under the supervision of a technician sent by the dealer.

- Check that there is a power socket near the installation area which allows to easily connect the device to the power grid.
- The use of extension cords and sockets must be in compliance with the characteristics of the device.
- The position of the machine must be selected so that it cannot be hit by jets of steam, water or other liquids.
- The machine must be used indoors only.

• Preparation of installation area

The installation site must be indoors.

• Equipment check

The packaging contains:

- Fixed aspirator for nail filing powders “Helios 280”;
- Instruction manual .

• Installation procedures

Remove the filter from the machine.

Use the supplied screws to fix Helios 280 to the lower part of the table top, using the special threaded inserts.

Install the filter and position the grid on the work surface.

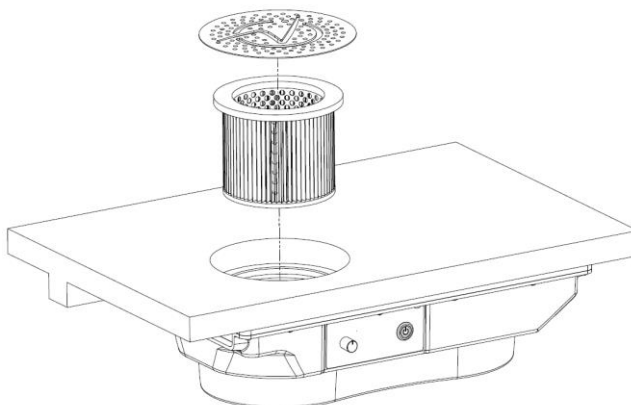
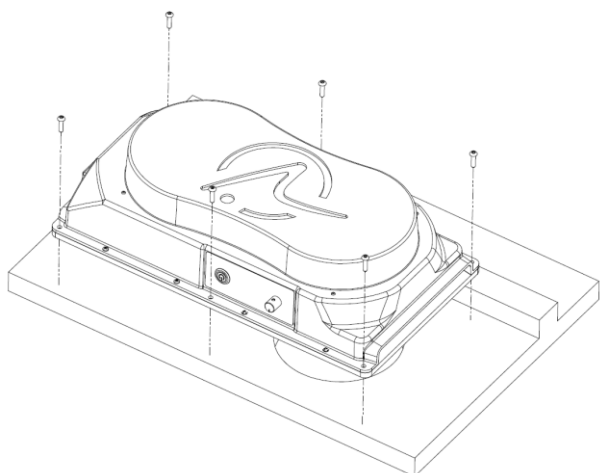



• Unpacking

Once the cardboard packaging has been removed, the aspirator Helios 280 can be lifted and moved.

WARNING! *Do not use knives or cutters to open the box in order to avoid any damage to the product.*

• Assembly

WARNING! *The assembly area must be clean and clear*

The assembly area shall have the following characteristics:

- Level support surface, non-yielding
- an electric power distribution socket suitable for the characteristics of the article (see identification label) made in compliance with IEC standards.

• Electrical connection

WARNING! *Electrical devices cannot be used in a potentially explosive or flammable atmosphere.*

WARNING! *Cables must be positioned in such a way that they are not pinched, trapped, stretched, stepped on, bent, wet, or in the way of moving parts.*

WARNING! *The power cable must not hinder the operator.*

WARNING! *Check that power grid voltage and frequency correspond to the ones compatible with the device (see identification label).*

- Prepare a SCHUKO socket
- Connect the power cable to the power grid.

Before connecting the machine to the electrical system, make sure that the switch is turned "OFF".

WARNING! *Connect only to grounding system sockets and adequate protection devices.*

It is important to verify that the grounding system is compliant with current legislation. In case of doubts, please ask to qualified personnel an accurate supervision of the system. Always verify that the location where the machine is located is equipped with a circuit breaker.



- **Power grid connection procedure**

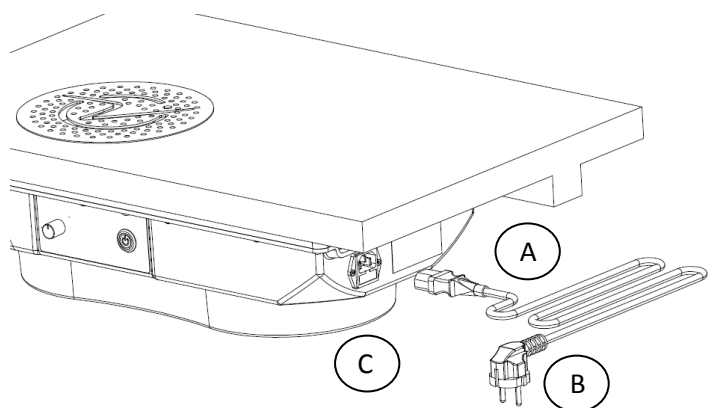

Insert extremity A in the connector C located on the side of the machine and plug B in the socket. Plug and extremity A must be held firmly on the rigid part and the cable must never be pulled to extract them. It is necessary to use dry hands and not be barefoot during plug connection and disconnection.

In case of damages to the power cable, it must be replaced by high qualified personnel using a special cable available at the manufacturer or in the authorized service centers

- **Functional testing**

WARNING! *The following check must be periodically repeated to verify the efficiency of the product.*

Before using the device:

- Perform the "periodic test" planned in the maintenance chapter;
- If the test is successful, the device is ready to be put into regular service, otherwise contact customer service immediately.



OPERATION AND USE

- **Warning:**

Sanitize the device according to the procedures described in the section **CLEANING AND SANITATION**.

DO NOT SUCK WITHOUT FILTER ELEMENT INSTALLED!

Do not use the device for conditions or purposes other than which it was intended.
“Helios 280” has been designed and built exclusively as machine for professional use for the suction of nail filings powder in beauty centers.

This machine is suitable for high stresses for industrial applications according to EN60335-1 standards.

Room temperature during use: +10°C till +45°C

Do not operate the controls with damp or wet parts of the body.

- **Starting, regulation and turning off**

When the machine has been correctly connected to the power grid, it is possible to start it by proceeding as follows:

Make sure the filter is positioned correctly;

Put the main switch on “ON” to turn on the machine;

Rotate the regulation knob clockwise to increase the suction power and counterclockwise to reduce the suction power;

Place the main switch on OFF to turn off the machine.

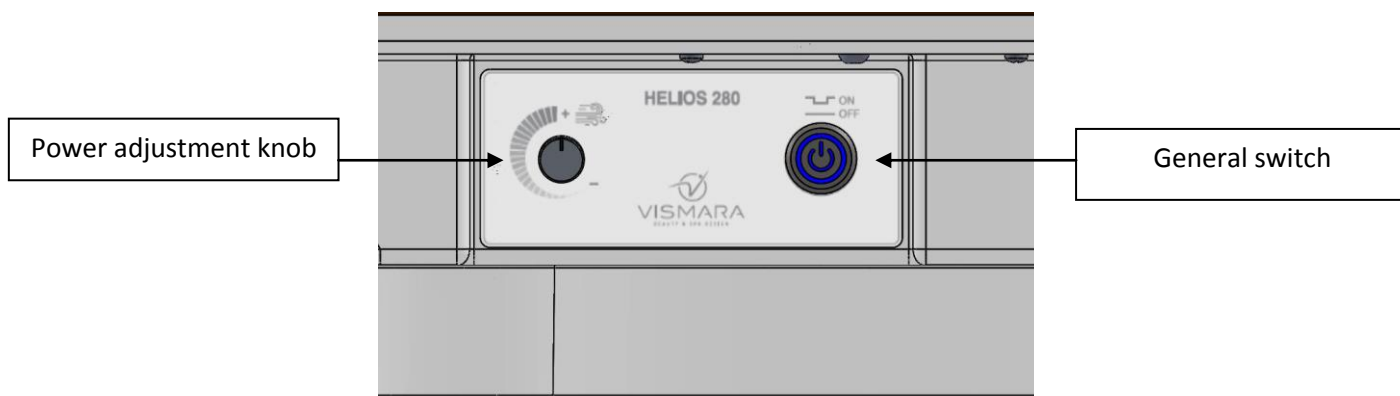



CLEANING AND SANITIZATION

- **Cleaning**

Cleaning of the product must be effected when the device is switched off, totally cooled and disconnected. Clean the external surface using a damp rag, do not position the device under the jet of the water. Do not use solvent or chemical additive for the cleaning of the external parts of the device.

- **Cleaning of the filters**

The filter must be cleaned with special brushes and the aid of a vacuum cleaner to remove dust residues, taking care not to damage the filter.

The filter is not washable. Do not use additive.

Do not use compressed air.

- **Filter replacement**

Pull out the used filter and repack in a specific bag for disposal.

Place the new filter in the appropriate housing.

- **Sanitization**

The manufacturer suggests to sanitize the product after the cleaning of the surfaces using a 10% solution of Amuchina .

- **Cleaning intervals and sanitizing**

The sanitation intervals are defined by the user based on the use frequency and in any case considering the instructions contained in this manual and on the sanitizing products used.



MAINTENANCE

• Periodic test

The user personnel must inspect the aspirator Helios 280 after every use checking that there are no damaged part or signs of wear.

The user personnel must inspect the device at least twice a year; the inspection must include the visual check for any damage that could compromise the integrity and the correct functioning of the device, such as:

- Integrity of power cables and plugs
- Connection of the power cable
- External surfaces condition, checking the absence of defects that could generate electrical and mechanical danger situations
- General cleaning of the product
- Condition of the filter and if necessary arrange the replacement.

WARNING! *If you find a damage, contact the authorized assistance service before working on the machine.*

WARNING! *If you find a damage, take the product out of service till its repair or replacement.*

WARNING! *Cleaning and maintenance operations must be carried out with device disconnected from the power supply.*

WARNING! *The device can contain harmful dust. Maintenance, emptying and replacement of the filter are allowed to authorized technical personnel only, equipped with the adequate protection equipment.*

• Extraordinary maintenance

Extraordinary maintenance is required in case of malfunctions or breakages due to intense use, unforeseeable accidents or inappropriate use of the machine. In any case, before starting an extraordinary intervention, always consult the manufacturer to confirm the correctness of the planned intervention.

• Technical assistance

Intervention requests of technical customer service must be forwarded to your own dealer. al proprio rivenditore.

Indicating:

- Model and serial number
- Defects found
- Correct address of the place where the device is installed



WARNING! All technical assistance interventions must strictly be carried out by the authorized dealer. Technical assistance interventions carried out by unauthorized individuals may compromise the operation of the device and may cause damage to things or people. Vismara s.r.l. takes no responsibility for damage to things or people, due to technical assistance interventions carried out by unauthorized personnel.

- **Dismissal**

When the product is stored for a long period it is necessary to:

- Place it in a dry place, protected from the sun;
- Protect it from dust by covering it with a nylon sheet;

- **Demolition and disposal**

The materials of the table are essentially:

- steel
- plastic ABS material and wood
- electronic components

RAEE directive: for EEC Countries only. According to the European directive regarding waste of electrical and electronic equipment and its implementation in accordance with national regulations, exhausted electrical equipment must be collected separately, in order to be recycled in an eco-friendly way. The product, when reaches the end of its life, must not be dispersed in the environment or thrown away in domestic waste, but it must be disposed in authorized collection centers for differentiated waste (contact the competent local authorities for the product disposal in accordance with the law).

Proper disposal of the product contributes to health and environment protection.

Illegal waste disposal involves penalties for transgressors.



WARRANTY

The device is covered by a warranty for a period of 12 months.

During the warranty period, the manufacturer undertakes to eliminate any faults and / or defects in the device, as long as the product has been correctly used, in compliance with the instructions of this Manual.

For a service intervention in warranty, please contact your dealer.

The replacement of parts with others found in the market, which do not comply with Vismara s.r.l. specifications, or specially designed parts not supplied by Vismara s.r.l., will void the warranty. Improper use of the device will void the warranty as well.

IMPORTANT! *Keep a copy of the delivery document or purchase receipt. The date shown on the document shall attest the beginning of the warranty period.*

F.A.Q.

The analysis and verification activities listed below refer to technical and qualified personnel.

ANOMALY	CAUSE	SOLUTION
The aspirator does not start	Lack of power	Check that the plug is inserted into the socket
	Damaged power cable, motor or electronic board	Contact an authorized Customer Service
Suction capacity is insufficient	Clogged filter	Carry-out the ordinary maintenance
		Filter cleaning / replacement
Suction power doesn't vary	Regulator break	Contact an authorized Customer Service
Dust coming out of the machine	Clogged or damaged filter	Contact an authorized Customer Service

For all other kind of anomalies contact the technical assistance.



WIRING DIAGRAM

220 V

50/60Hz

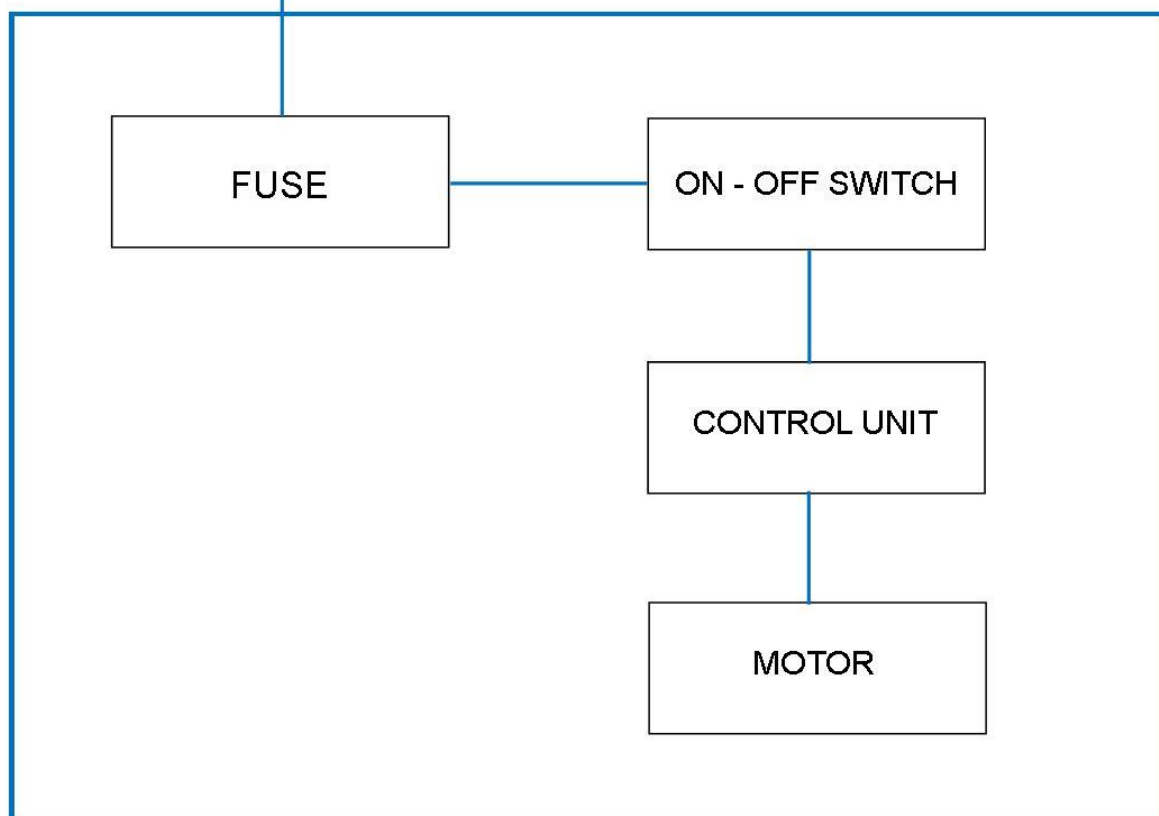



Free page intentionally left white



Vismara s.r.l

Via Salvo d'Acquisto 19, 20833 Paina di Giussano (MB)

Tel: +39 0362 236169

info@vismarabenessere.it

<http://www.vismarabenessere.it>

Spazio per il rivenditore